

TPS61193-Q1 High-Performance 3-Channel LED Driver for Automotive Lighting

1 Features

- Qualified for Automotive Applications
- AEC-Q100 Qualified With the Following Results:
 - Device Temperature Grade 1: -40°C to 125°C Ambient Operating Temperature Range
 - Device HBM ESD Classification Level 2
 - Device CDM ESD Classification Level C4B
- Input Voltage Operating Range 4.5 V to 40 V
- Three High-Precision Current Sinks
 - Current Matching 1% (typical)
 - Output Current up to 100 mA per Channel
 - Outputs can be combined externally for higher current per string
- High Dimming Ratio 10 000:1 at 200 Hz
- Integrated DC-DC for LED String Power
 - Boost and SEPIC modes supported
 - Output Voltage up to 45 V
 - Switching Frequency 300 kHz to 2.2 MHz
- EMI Minimization
 - DC-DC Synchronization Input
 - Spread Spectrum Option
- Extensive Fault Detection Features
 - Fault Output
 - Input Voltage OVP and UVLO
 - Open and Shorted LED Fault Detection
 - Thermal Shutdown
- Minimum Number of External Components

2 Applications

Automotive Infotainment, Instrument Clusters, and Backlighting Systems

3 Description

The TPS61193-Q1 is an automotive high-efficiency, low-EMI, easy-to-use LED driver with integrated DC-DC converter. DC-DC converter supports both boost and SEPIC mode operation. Device has three high-precision current sinks that can provide high dimming ratio brightness control with a PWM input signal.

The DC-DC converter has adaptive output voltage control based on the LED current sink headroom voltages. This feature minimizes the power consumption by adjusting the voltage to the lowest sufficient level in all conditions. DC-DC supports spread spectrum for switching frequency and an external synchronization with dedicated pin. The high switching frequency allows the TPS61193-Q1 to avoid disturbance for AM radio band.

The input voltage range for the TPS61193-Q1 is from 4.5 V to 40 V to support automotive stop/start and load dump condition. The device supports PWM brightness dimming ratio 10 000:1 for 200-Hz input PWM frequency. The TPS61193-Q1 integrates extensive fault detection features.

Device Information⁽¹⁾

PART NUMBER	PACKAGE	BODY SIZE (NOM)
TPS61193-Q1	HTSSOP (20)	6.50 mm x 4.40 mm

(1) For all available packages, see the orderable addendum at the end of the data sheet.

Simplified Schematic

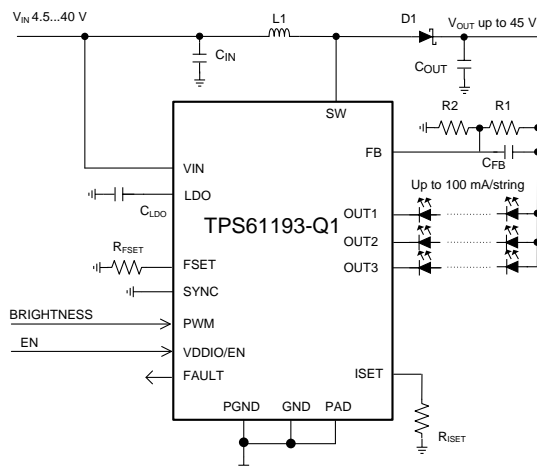

System Efficiency

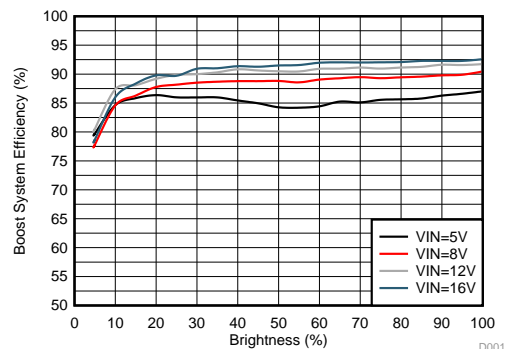

D001



Table of Contents

1 Features 1 2 Applications 1 3 Description 1 4 Revision History 2 5 Pin Configuration and Functions 3 6 Specifications 5 6.1 Absolute Maximum Ratings 5 6.2 ESD Ratings 5 6.3 Recommended Operating Conditions 5 6.4 Thermal Information 6 6.5 Electrical Characteristics 6 6.6 Internal LDO Electrical Characteristics 6 6.7 Protection Electrical Characteristics 6 6.8 Current Sinks Electrical Characteristics 7 6.9 PWM Brightness Control Electrical Characteristics .. 7 6.10 Boost and SEPIC Converter Characteristics 7 6.11 Logic Interface Characteristics 8 6.12 Typical Characteristics 9	7 Detailed Description 10 7.1 Overview 10 7.2 Functional Block Diagram 11 7.3 Feature Description 12 7.4 Device Functional Modes 18 8 Application and Implementation 20 8.1 Application Information 20 8.2 Typical Applications 20 9 Power Supply Recommendations 25 10 Layout 26 10.1 Layout Guidelines 26 10.2 Layout Example 27 11 Device and Documentation Support 28 11.1 Documentation Support 28 11.2 Trademarks 28 11.3 Electrostatic Discharge Caution 28 11.4 Glossary 28 12 Mechanical, Packaging, and Orderable Information 28
--	---

4 Revision History

DATE	REVISION	NOTES
October 2015	*	Initial

5 Pin Configuration and Functions

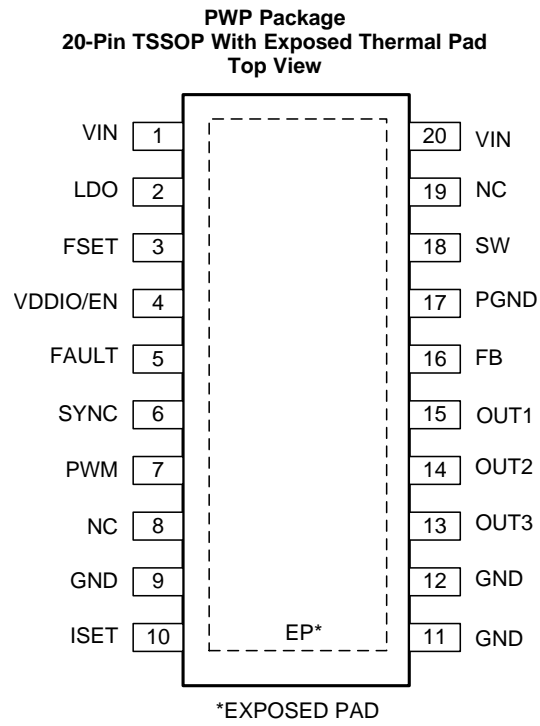

Pin Functions

PIN		TYPE ⁽¹⁾	DESCRIPTION
NUMBER	NAME		
1	VIN	A	Input power pin
2	LDO	A	Output of internal LDO; connect a 1- μ F decoupling capacitor between this pin and noise-free ground.
3	FSET	A	DC-DC (boost or SEPIC) switching frequency setting resistor.
4	VDDIO/EN	I	Enable input for the device as well as supply input (VDDIO) for digital pins
5	FAULT	OD	Fault signal output. If unused, the pin may be left floating.
6	SYNC	I	Input for synchronizing boost. If synchronization is not used, connect this pin to GND to disable spread spectrum or to VDDIO/EN to enable spread spectrum.
7	PWM	I	PWM dimming input.
8	NC		No connect
9	GND	G	Ground.
10	ISET	A	LED current setting resistor.
11	GND	G	Ground
12	GND	G	Ground
13	OUT3	A	Current sink output This pin must be connected to GND if not used.
14	OUT2	A	Current sink output This pin must be connected to GND if not used.
15	OUT1	A	Current sink output This pin must be connected to GND if not used.
16	FB	A	DC-DC (boost or SEPIC) feedback input
17	PGND	G	DC-DC (boost or SEPIC) power ground
18	SW	A	DC-DC (boost or SEPIC) switch pin
19	NC	A	No connect
20	VIN	A	Input power pin

(1) A: Analog pin, G: Ground pin, P: Power pin, I: Input pin, I/O: Input/Output pin, O: Output pin, OD: Open Drain pin

6 Specifications

6.1 Absolute Maximum Ratings

Over operating free-air temperature range (unless otherwise noted)⁽¹⁾⁽²⁾

		MIN	MAX	UNIT
Voltage on pins	VIN, SW, FB	-0.3	50	V
	OUT1, OUT2, OUT3	-0.3	45	
	LDO, SYNC, FSET, ISET, PWM, VDDIO/EN, FAULT	-0.3	5.5	
Continuous power dissipation ⁽³⁾		Internally Limited		
Ambient temperature range T_A ⁽⁴⁾		-40	125	°C
Junction temperature range T_J ⁽⁴⁾		-40	150	
Maximum lead temperature (soldering)			See ⁽⁵⁾	
Storage temperature, T_{stg}		-65	150	°C

- Stresses beyond those listed under absolute maximum ratings may cause permanent damage to the device. These are stress ratings only, and functional operation of the device at these or any other conditions beyond those indicated under recommended operating conditions is not implied. Exposure to absolute-maximum-rated conditions for extended periods may affect device reliability.
- All voltages are with respect to the potential at the GND pins.
- Internal thermal shutdown circuitry protects the device from permanent damage. Thermal shutdown engages at $T_J = 165^\circ\text{C}$ (typical) and disengages at $T_J = 145^\circ\text{C}$ (typical).
- In applications where high power dissipation and/or poor package thermal resistance is present, the maximum ambient temperature may have to be derated. Maximum ambient temperature (T_{A-MAX}) is dependent on the maximum operating junction temperature ($T_{J-MAX-OP} = 150^\circ\text{C}$), the maximum power dissipation of the device in the application (P_{D-MAX}), and the junction-to ambient thermal resistance of the part/package in the application ($R_{\theta JA}$), as given by the following equation: $T_{A-MAX} = T_{J-MAX-OP} - (R_{\theta JA} \times P_{D-MAX})$.
- For detailed soldering specifications and information, please refer to the *PowerPAD™ Thermally Enhanced Package Application Note (SLMA002)*.

6.2 ESD Ratings

		VALUE	UNIT	
$V_{(ESD)}$ Electrostatic discharge	Human-body model (HBM), per AEC Q100-002 ⁽¹⁾	±2000	V	
	Charged-device model (CDM), per AEC Q100-011	All other pins		±500
		Corner pins (1,10,11,20)		±750

- AEC Q100-002 indicates that HBM stressing shall be in accordance with the ANSI/ESDA/JEDEC JS-001 specification.

6.3 Recommended Operating Conditions

Over operating free-air temperature range (unless otherwise noted)⁽¹⁾

		MIN	MAX	UNIT
Voltage on pins	VIN	4.5	45	V
	SW	0	45	
	OUT1, OUT2, OUT3	0	40	
	FB, FSET, LDO, ISET, VDDIO/EN, FAULT	0	5.25	
	SYNC, PWM	0	VDDIO/EN	

- All voltages are with respect to the potential at the GND pins.

6.4 Thermal Information

THERMAL METRIC ⁽¹⁾		PWP (TSSOP) (20 PINS)	UNIT
R _{θJA}	Junction-to-ambient thermal resistance ⁽²⁾	44.2	°C/W
R _{θJctop}	Junction-to-case (top) thermal resistance	26.5	
R _{θJB}	Junction-to-board thermal resistance	22.4	
ψ _{JT}	Junction-to-top characterization parameter	0.9	
ψ _{JB}	Junction-to-board characterization parameter	22.2	
R _{θJcbot}	Junction-to-case (bottom) thermal resistance	2.5	

- (1) For more information about traditional and new thermal metrics, see the *Semiconductor and IC Package Thermal Metrics* application report, [SPRA953](#).
- (2) Junction-to-ambient thermal resistance is highly application and board-layout dependent. In applications where high maximum power dissipation exists, special care must be paid to thermal dissipation issues in board design.

6.5 Electrical Characteristics⁽¹⁾⁽²⁾

T_J = -40°C to 125°C (unless otherwise noted).

PARAMETER		TEST CONDITIONS	MIN	TYP	MAX	UNIT
I _Q	Standby supply current	Device disabled, V _{VDDIO/EN} = 0 V, V _{IN} = 12 V		4.5	20	μA
	Active supply current	V _{IN} = 12 V, V _{OUT} = 26 V, output current 80 mA/channel, converter F _{sw} = 300 kHz		5	12	mA
V _{POR_R}	Power-on reset rising threshold	LDO pin voltage.			2.7	V
V _{POR_F}	Power-on reset falling threshold	LDO pin voltage.	1.5			V
T _{TSD}	Thermal shutdown threshold		150	165	175	°C
T _{TSD_HYST}	Thermal shutdown hysteresis			20		°C

- (1) All voltages are with respect to the potential at the GND pins.
- (2) Minimum and maximum limits are specified by design, test, or statistical analysis.

6.6 Internal LDO Electrical Characteristics

T_J = -40°C to 125°C (unless otherwise noted).

PARAMETER		TEST CONDITIONS	MIN	TYP	MAX	UNIT
V _{LDO}	Output voltage	V _{IN} = 12 V	4.15	4.3	4.55	V
V _{DR}	Dropout voltage		120	300	430	mV
I _{SHORT}	Short circuit current			50		mA

6.7 Protection Electrical Characteristics

T_J = -40°C to 125°C (unless otherwise noted).

PARAMETER		TEST CONDITIONS	MIN	TYP	MAX	UNIT
V _{OVP}	VIN OVP threshold voltage		41	42	44	V
V _{UVLO}	VIN UVLO			4.0		V
V _{UVLO_HYST}	VIN UVLO hysteresis			100		mV
	LED short detection threshold		5.6	6	7	V

6.8 Current Sinks Electrical Characteristics

 $T_J = -40^{\circ}\text{C}$ to 125°C (unless otherwise noted).

PARAMETER		TEST CONDITIONS	MIN	TYP	MAX	UNIT
I_{LEAKAGE}	Leakage current	Outputs OUT1 to OUT3 $V_{\text{OUTx}} = 45\text{ V}$		0.1	5	μA
I_{MAX}	Maximum current	OUT1, OUT2, OUT3		100		mA
I_{OUT}	Output current accuracy	$I_{\text{OUT}} = 100\text{ mA}$	-5%		5%	
I_{MATCH}	Output current matching ⁽¹⁾	$I_{\text{OUT}} = 100\text{ mA}$, PWM duty = 100%		1%	5%	
V_{SAT}	Saturation voltage ⁽²⁾	$I_{\text{OUT}} = 100\text{ mA}$		0.4	0.7	V

- (1) Output Current Accuracy is the difference between the actual value of the output current and programmed value of this current. Matching is the maximum difference from the average. For the constant current sinks on the part (OUTx), the following are determined: the maximum output current (MAX), the minimum output current (MIN), and the average output current of all outputs (AVG). Matching number is calculated: $(\text{MAX}-\text{MIN})/\text{AVG}$. The typical specification provided is the most likely norm of the matching figure for all parts. LED current sinks were characterized with 1-V headroom voltage. Note that some manufacturers have different definitions in use.
- (2) Saturation voltage is defined as the voltage when the LED current has dropped 10% from the value measured at 1 V.

6.9 PWM Brightness Control Electrical Characteristics

 $T_J = -40^{\circ}\text{C}$ to 125°C (unless otherwise noted).

PARAMETER		TEST CONDITIONS	MIN	TYP	MAX	UNIT
f_{PWM}	PWM input frequency		100		20 000	Hz
$t_{\text{ON/OFF}}$	Minimum on/off time	$I_{\text{OUT}} = 100\text{ mA}$.			0.5	μs

6.10 Boost and SEPIC Converter Characteristics

 $T_J = -40^{\circ}\text{C}$ to 125°C (unless otherwise noted).

Unless otherwise specified: $V_{\text{IN}} = 12\text{ V}$, $V_{\text{EN/VDDIO}} = 3.3\text{ V}$, $L = 22\text{ }\mu\text{H}$, $C_{\text{IN}} = 2 \times 10\text{ }\mu\text{F}$ ceramic and $33\text{ }\mu\text{F}$ electrolytic, $C_{\text{OUT}} = 2 \times 10\text{-}\mu\text{F}$ ceramic and $33\text{-}\mu\text{F}$ electrolytic, $D = \text{NRVB460MFS}$, $f_{\text{SW}} = 300\text{ kHz}$.

PARAMETER		TEST CONDITIONS	MIN	TYP	MAX	UNIT
V_{IN}	Input voltage		4.5		40	V
V_{OUT}	Output voltage		6		45	
$f_{\text{SW_MIN}}$	Minimum switching frequency (central frequency if spread spectrum is enabled)	Defined by R_{FSET} resistor		300		kHz
$f_{\text{SW_MAX}}$	Maximum switching frequency (central frequency if spread spectrum is enabled)			2 200		kHz
$V_{\text{OUT}}/V_{\text{IN}}$	Conversion ratio				10	
T_{OFF}	Minimum switch OFF time	$f_{\text{SW}} \geq 1.15\text{ MHz}$			55	ns
$I_{\text{SW_MAX}}$	SW current limit		1.8	2.0	2.2	A
$R_{\text{DS(on)}}$	FET $R_{\text{DS(on)}}$	Pin-to-pin		240	400	$\text{m}\Omega$
f_{SYNC}	External SYNC frequency		300		2 200	kHz
$t_{\text{SYNC_ON_MIN}}$	External SYNC minimum on time			150		ns
$t_{\text{SYNC_OFF_MIN}}$	External SYNC minimum off time			150		ns

6.11 Logic Interface Characteristics

$T_J = -40^{\circ}\text{C}$ to 125°C (unless otherwise noted).

PARAMETER		TEST CONDITIONS	MIN	TYP	MAX	UNIT
LOGIC INPUT VDDIO/EN						
V_{IL}	Input low level				0.4	V
V_{IH}	Input high level		1.65			
I_i	Input current		-1	5	30	μA
LOGIC INPUT SYNC/FSET, PWM						
V_{IL}	Input low level				$0.2 \times \text{VDDIO/EN}$	V
V_{IH}	Input high level		$0.8 \times \text{VDDIO/EN}$			
I_i	Input current		-1		1	μA
LOGIC OUTPUT FAULT						
V_{OL}	Output low level	Pullup current 3 mA		0.3	0.5	V
$I_{LEAKAGE}$	Output leakage current	$V = 5.5 \text{ V}$			1	μA

6.12 Typical Characteristics

Unless otherwise specified: D = NRVB460MFS, T = 25°C

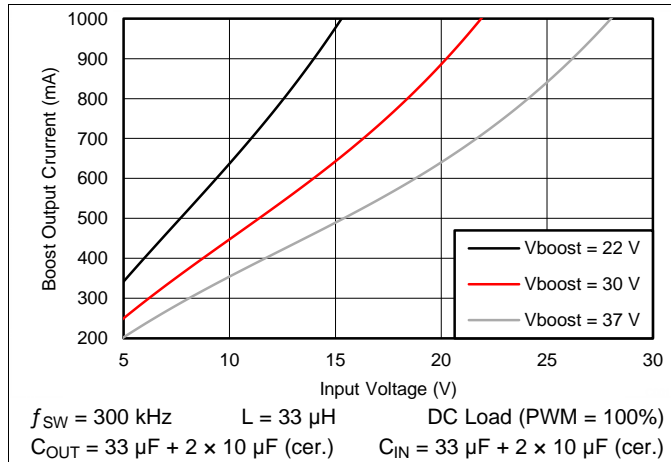

Figure 1. Maximum Boost Current

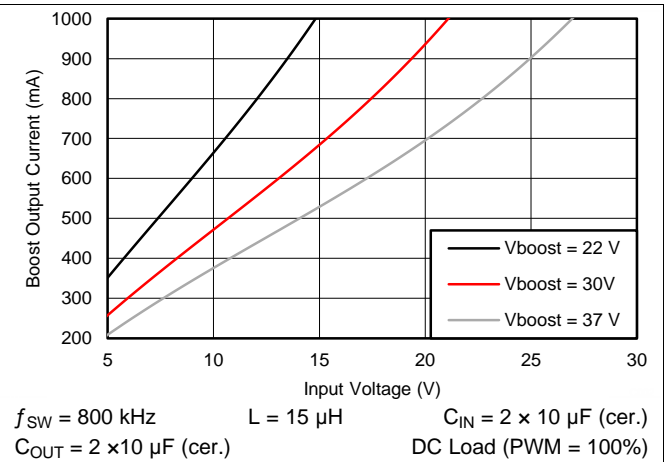

Figure 2. Maximum Boost Current

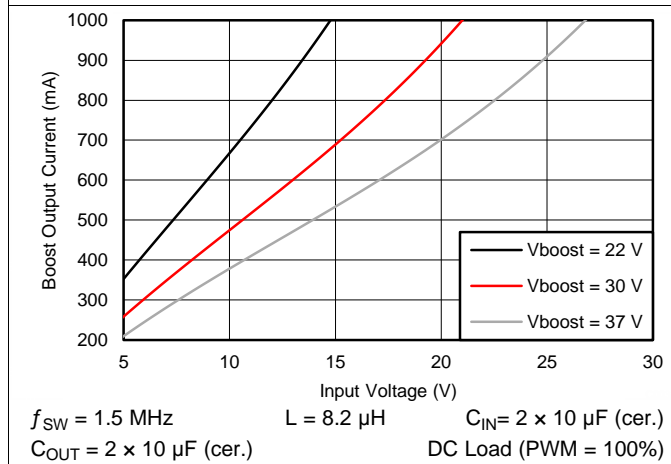

Figure 3. Maximum Boost Current

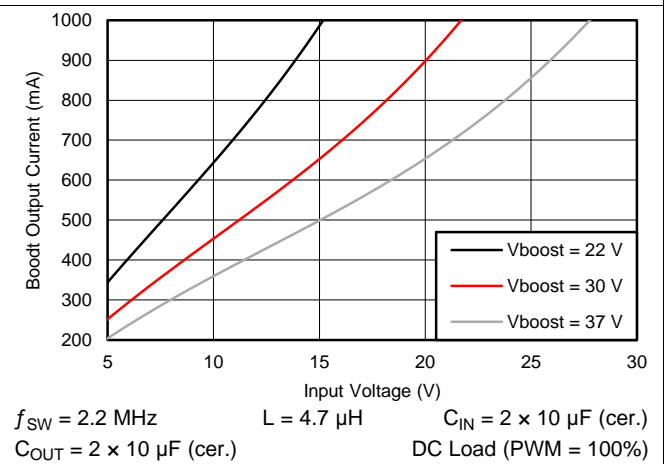

Figure 4. Maximum Boost Current

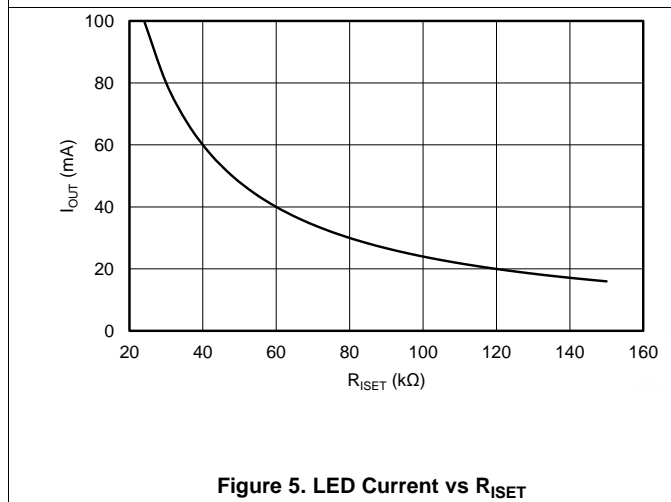

Figure 5. LED Current vs R_{ISET}

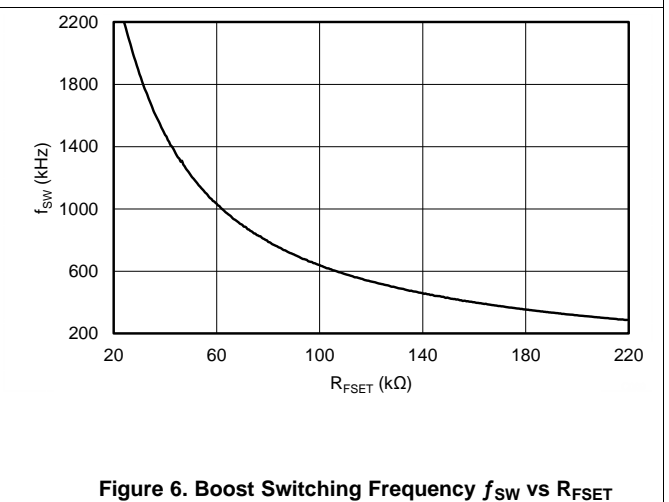

Figure 6. Boost Switching Frequency f_{SW} vs R_{FSET}

7 Detailed Description

7.1 Overview

TPS61193-Q1 is a highly integrated LED driver for automotive infotainment, lighting system and medium-sized LCD backlight applications. It includes a DC-DC with an integrated FET, supporting both boost and SEPIC modes, an internal LDO enabling direct connection to battery without need for a pre-regulated supply and three LED current sinks. The VDDIO/EN pin provides the supply voltage for digital IOs (PWM and SYNC inputs) and at the same time enables the device.

The switching frequency on the DC-DC converter is set by a resistor connected to the FSET pin. The maximum voltage of the DC-DC is set by a resistive divider connected to the FB pin. For the best efficiency the output voltage is adapted automatically to the minimum necessary level needed to drive the LED strings. This is done by monitoring LED output voltage drop in real time. For EMI reduction and control two optional features are available:

- Spread spectrum, which reduces EMI noise around the switching frequency and its harmonic frequencies
- DC-DC can be synchronized to an external frequency connected to SYNC pin

The three constant current sinks OUT1, OUT2 and OUT3 provide LED current up to 100mA. Value for the current per OUT pin is set with a resistor connected to ISET pin. Current sinks that are not used must be connected to ground. Grounded current sink is disabled and excluded from adaptive voltage detection loop.

Brightness is controlled with the PWM input. Frequency range for the input PWM is from 100 Hz to 20 kHz. LED output PWM follows the input PWM so the output frequency is equal to the input frequency.

TPS61193-Q1 has extensive fault detection features :

- Open-string and shorted LED detections
 - LED fault detection prevents system overheating in case of open or short in some of the LED strings
- V_{IN} input overvoltage protection
 - Threshold sensing from VIN pin
- V_{IN} input undervoltage protection
 - Threshold sensing from VIN pin
- Thermal shutdown in case of die over-temperature

Fault condition is indicated through the FAULT output pin.

7.3 Feature Description

7.3.1 Integrated DC-DC Converter

The TPS61193-Q1 DC-DC converter generates supply voltage for the LEDs and can operate in boost mode or in SEPIC mode. The maximum output voltage V_{OUT_MAX} is defined by an external resistive divider (R_1 , R_2).

V_{OUT_MAX} voltage should be chosen based on the maximum voltage required for LED strings. Recommended maximum voltage is about 30% higher than maximum LED string voltage. Initial output voltage is about 88% of V_{OUT_MAX} voltage. DC-DC output voltage is adjusted automatically based on LED current sink headroom voltage. Maximum output voltage can be calculated with [Equation 1](#):

$$V_{OUT_MAX} = \left(\frac{V_{BG}}{R_2} + 0.0387 \right) \times R_1 + V_{BG}$$

where

- $V_{BG} = 1.2 \text{ V}$
- R_2 recommended value is 130 k Ω
- Resistor values are in k Ω

(1)

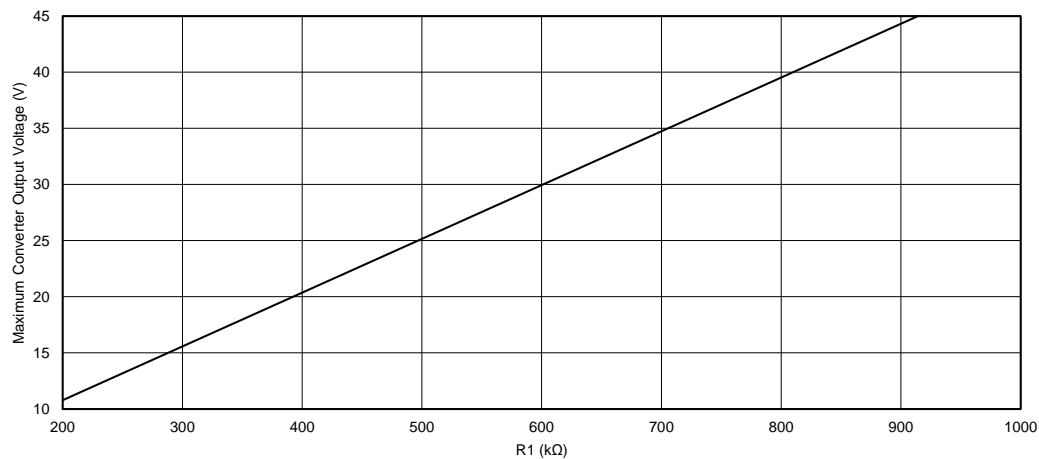

Figure 7. Maximum Converter Output Voltage vs R1 Resistance

The converter is a current mode DC-DC converter, where the inductor current is measured and controlled with the feedback. Switching frequency is adjustable between 250 kHz and 2.2 MHz with R_{FSET} resistor as [Equation 2](#):

$$f_{SW} = 67600 / (R_{FSET} + 6.4)$$

where

- f_{SW} is switching frequency, kHz
- R_{FSET} is frequency setting resistor, k Ω

(2)

In most cases lower frequency has higher system efficiency. DC-DC internal parameters are chosen automatically according to the selected switching frequency (see [Table 2](#)) to ensure stability. In boost mode a 15 pF capacitor C_{FB} must be placed across resistor R_1 when operating in 300 kHz to 500 kHz range (see [Typical Application for 3 LED Strings](#)). When operating in the 1.8 MHz to 2.2 MHz range $C_{FB} = 4.7 \text{ pF}$.

Feature Description (continued)

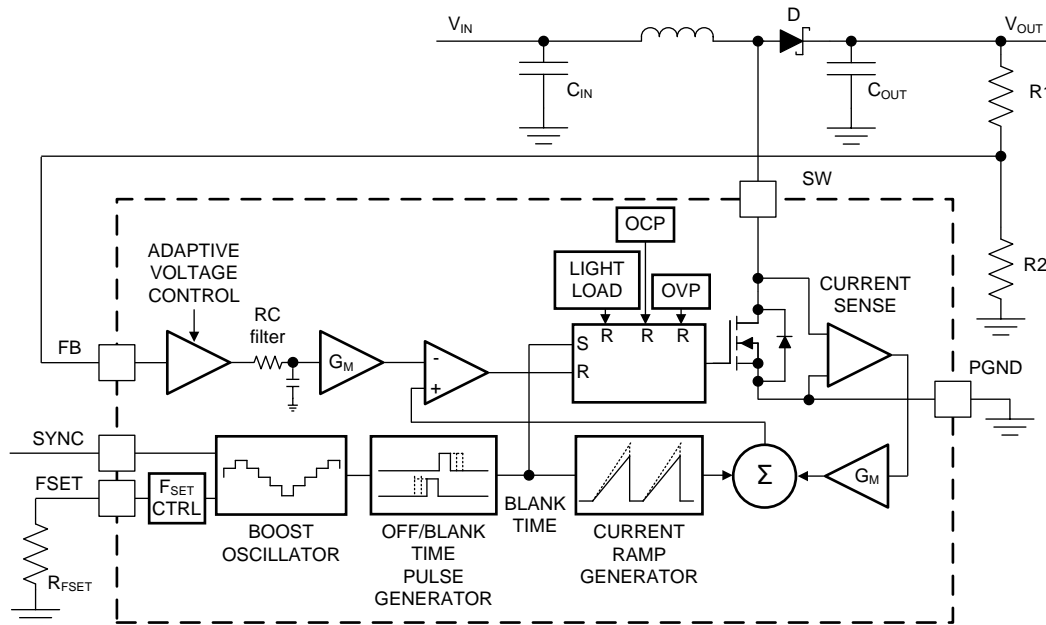

Figure 8. Boost Block Diagram

DC-DC can be driven by an external SYNC signal between 300 kHz and 2.2 MHz. If the external synchronization input disappears, DC-DC continues operation at the frequency defined by R_{FSET} resistor. When external frequency disappears and SYNC pin level is low, converter continues operation without spread spectrum immediately. If SYNC remains high, converter continues switching with spread spectrum enabled after 256 μs.

External SYNC frequency must be 1.2 to 1.5 times higher than the frequency defined by R_{FSET} resistor. Minimum frequency setting with R_{FSET} is 250 kHz to support 300 kHz switching with external clock.

The optional spread spectrum feature (±3% from central frequency, 1-kHz modulation frequency) reduces EMI noise at the switching frequency and its harmonic frequencies. When external synchronization is used, spread spectrum is not available.

Table 1. DC-DC Synchronization Mode

SYNC PIN INPUT	MODE
Low	Spread spectrum disabled
High	Spread spectrum enabled
300 to 2200 kHz frequency	Spread spectrum disabled, external synchronization mode

Table 2. DC-DC Parameters⁽¹⁾

RANGE	FREQUENCY (kHz)	TYPICAL INDUCTANCE (μH)	TYPICAL BOOST INPUT AND OUTPUT CAPACITORS (μF)	MINIMUM SWITCH OFF TIME (ns) ⁽²⁾	BLANK TIME (ns)	CURRENT RAMP (A/s)	CURRENT RAMP DELAY (ns)
1	300...480	33	2x10(cer.)+33(electr.)	150	95	24	550
2	480...1150	15	10(cer.)+33(electr.)	60	95	43	300
3	1150...1650	10	3x10(cer.)	40	95	79	0
4	1650...2200	4.7	3x10(cer.)	40	70	145	0

(1) Parameters are for reference only

(2) Due to current sensing comparator delay the actual minimum off time is 6 ns (typical) longer than in the table.

Converter SW pin DC current is limited to 2 A (typical). To support warm start transient condition the current limit is automatically increased to 2.5 A for a short period of 1.5 seconds when a 2-A limit is reached.

NOTE

Application condition where the 2-A limit is exceeded continuously is not allowed. In this case the current limit would be 2 A for 1.5 seconds followed by 2.5-A limit for 1.5 seconds, and this 3-second period repeats.

7.3.2 Internal LDO

The internal LDO regulator converts the input voltage at VIN to a 4.3-V output voltage for internal use. Connect a minimum of 1 μ F ceramic capacitor from LDO pin to ground, as close to the LDO pin as possible.

7.3.3 LED Current Sinks

7.3.3.1 Output Configuration

TPS61193-Q1 detects LED output configuration during start-up. Any current sink output connected to ground is disabled and excluded from the adaptive voltage control of the DC-DC and fault detections.

7.3.3.2 Current Setting

Maximum current for the LED outputs is controlled with external R_{ISET} resistor. R_{ISET} value for target maximum current can be calculated using [Equation 3](#):

$$R_{ISET} = 2342 / (I_{OUT} - 2.5)$$

where

- R_{ISET} is current setting resistor, k Ω
 - I_{LED} is output current per output, mA
- (3)

7.3.3.3 Brightness Control

TPS61193-Q1 controls the brightness of the display with conventional PWM. Output PWM directly follows the input PWM. Input PWM frequency can be in the range of 100 Hz to 20 kHz. Dimming ratio is calculated as ratio between the input PWM period and minimum on/off time (0.5 μ s).

7.3.4 Protection and Fault Detections

TPS61193-Q1 has fault detection for LED open and short, VIN input overvoltage protection (VIN_OVP), VIN undervoltage lockout (VIN_UVLO), and thermal shutdown (TSD).

7.3.4.1 Adaptive DC-DC Voltage Control and Functionality of LED Fault Comparators

Adaptive voltage control function adjusts the DC-DC output voltage to the minimum sufficient voltage for proper LED current sink operation. The current sink with highest V_F LED string is detected and DC-DC output voltage adjusted accordingly. DC-DC adaptive control voltage step size is defined by maximum voltage setting, $V_{STEP} = (V_{OUT_MAX} - V_{OUT_MIN}) / 256$. Periodic down pressure is applied to the target voltage to achieve better system efficiency.

Every LED current sink has 3 comparators for the adaptive DC-DC control and LED fault detections. Comparator outputs are filtered, filtering time is 1 μ s.

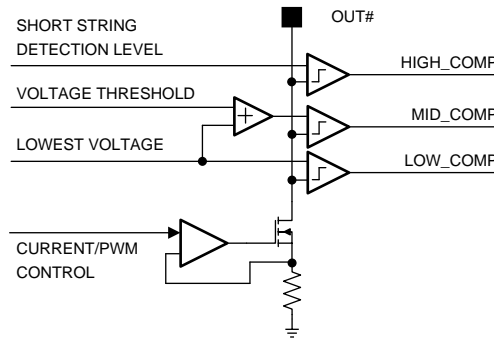

Figure 9. Comparators for Adaptive Voltage Control and LED Fault Detection

Figure 10 illustrates different cases which cause DC-DC voltage increase, decrease, or generate faults. In normal operation, voltage at all the OUT# pins is between LOW_COMP and MID_COMP levels and boost voltage stays constant. LOW_COMP level is the minimum for proper LED current sink operation, $1.1 \times V_{SAT} + 0.2 \text{ V}$ (typical). MID_COMP level is $1.1 \times V_{SAT} + 1.2 \text{ V}$ (typical) so typical headroom window is 1 V.

When voltage at all the OUT# pins increases above MID_COMP level, DC-DC voltage adapts downwards.

When voltage at any of the OUT# pins falls below LOW_COMP threshold, DC-DC voltage adapts upwards. In the condition where DC-DC voltage reaches the maximum and there are one or more outputs still below LOW_COMP level, an open LED fault is detected.

HIGH_COMP level, 6 V typical, is the threshold for shorted LED detection. When the voltage of one or more of the OUT# pins increases above HIGH_COMP level and at least one of the other outputs is within the normal headroom window, shorted LED fault is detected.

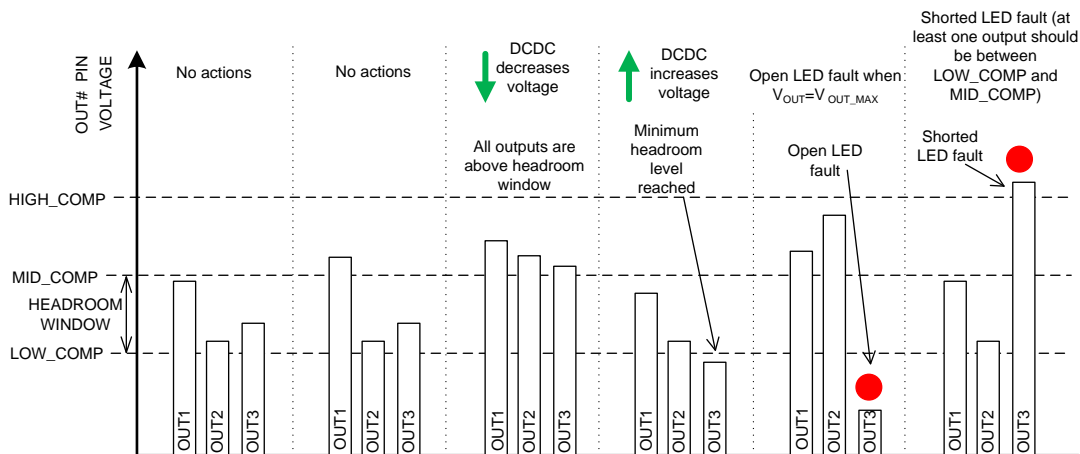

Figure 10. Protection and DC-DC Voltage Adaptation Algorithms

7.3.4.2 Overview of the Fault/Protection Schemes

Summary of TPS61193-Q1 fault detection behavior is shown in Table 3. Detected faults (excluding LED open or short) cause device to enter FAULT_RECOVERY state. In FAULT_RECOVERY the DC-DC and LED current sinks of the device are disabled and FAULT pin is pulled low. The device recovers automatically and enters normal operating mode (ACTIVE) after a recovery time of 100ms if the fault condition has disappeared. When recovery is successful, FAULT pin is released.

In case a LED fault is detected, device continues normal operation and only the faulty string is disabled. Fault is indicated via FAULT pin which can be released by toggling VDDIO/EN pin low for a short period of 2...20 μ s. LEDs are turned off for this period but device stays in ACTIVE mode. If VDDIO/EN is low longer, device goes to STANDBY and restarts when EN goes high again.

Table 3. Fault Detections

FAULT/ PROTECTION	FAULT NAME	THRESHOLD	FAULT PIN	FAULT RECOVERY STATE	ACTION
VIN overvoltage protection	VIN_OVP	1. $V_{IN} > 42\text{ V}$ 2. $V_{OUT} > V_{SET_DCDC} + 6..10\text{ V}$. V_{SET_DCDC} is voltage value defined by logic during adaptation	Yes	Yes	1. Overvoltage is monitored from the beginning of soft start. Fault is detected if the duration of overvoltage condition is 100 μ s minimum. 2. Overvoltage is monitored from the beginning of normal operation (ACTIVE mode). Fault is detected if over-voltage condition duration is 560 ms minimum (t_{filter}). After the first fault, detection filter time is reduced to 50 ms for following recovery cycles. When device recovers and has been in ACTIVE mode for 160 ms , filter time is increased back to 560 ms .
VIN undervoltage lockout	VIN_UVLO	Falling 3.9 V Rising 4 V	Yes	Yes	Detects undervoltage condition at VIN pin. Sensed in all operating modes. Fault is detected if undervoltage condition duration is 100 μ s minimum.
Open LED fault	OPEN_LED	LOW_COMP threshold	Yes	No	Detected if the voltage of one or more current sinks is below threshold level, and DC-DC adaptive control has reached maximum voltage. Open string is removed from the DC-DC voltage control loop and current sink is disabled. Fault pin is released by toggling VDDIO/EN pin. If VDDIO/EN is low for a period of 2...20 μ s, LEDs are turned off for this period but device stays ACTIVE. If VDDIO/EN is low longer, device goes to STANDBY and restarts when EN goes high again.
Shorted LED fault	SHORT_LED	Shorted string detection level 6 V	Yes	No	Detected if the voltage of one or more current sinks is above shorted string detection level and at least one OUTx voltage is within headroom window. Shorted string is removed from the DC-DC voltage control loop and current sink is disabled. Fault pin is released by toggling VDDIO/EN pin. If VDDIO/EN is low for a period of 2...20 μ s, LEDs are turned off for this period but device stays ACTIVE. If VDDIO/EN is low longer, device goes to STANDBY and restarts when EN goes high again..
Thermal protection	TSD	165°C Thermal shutdown hysteresis 20°C	Yes	Yes	Thermal shutdown is monitored from the beginning of soft start. Die temperature must decrease by 20°C for device to recover.

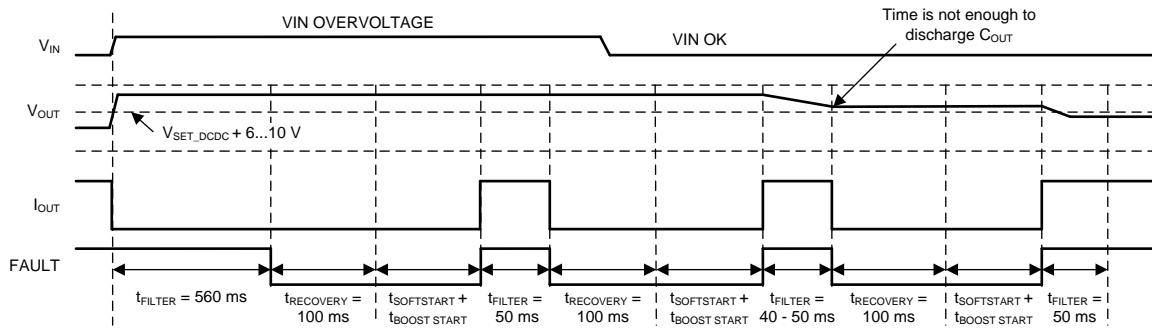

Figure 11. V_{IN} Overvoltage Protection (DC-DC OVP)

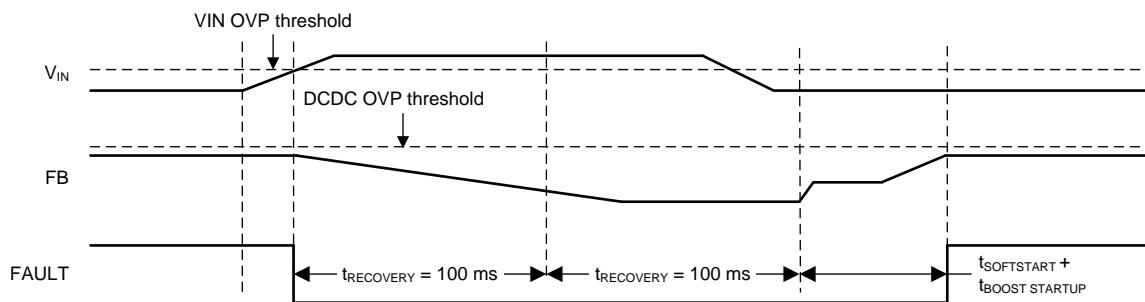

Figure 12. V_{IN} Overvoltage Protection (V_{IN} OVP)

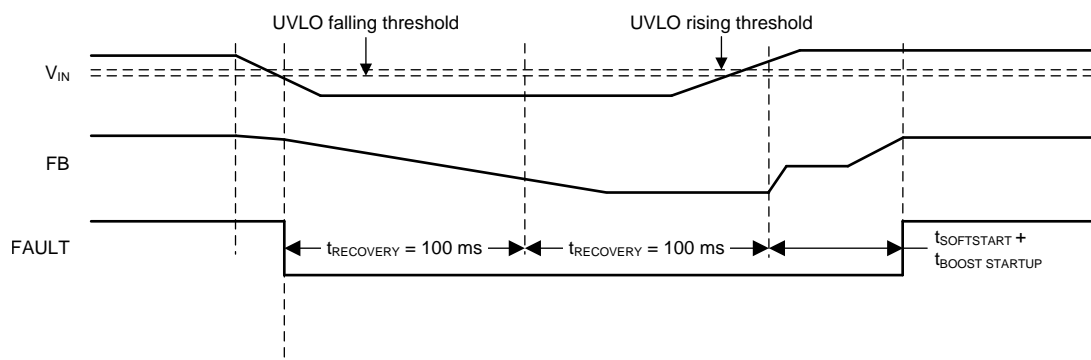
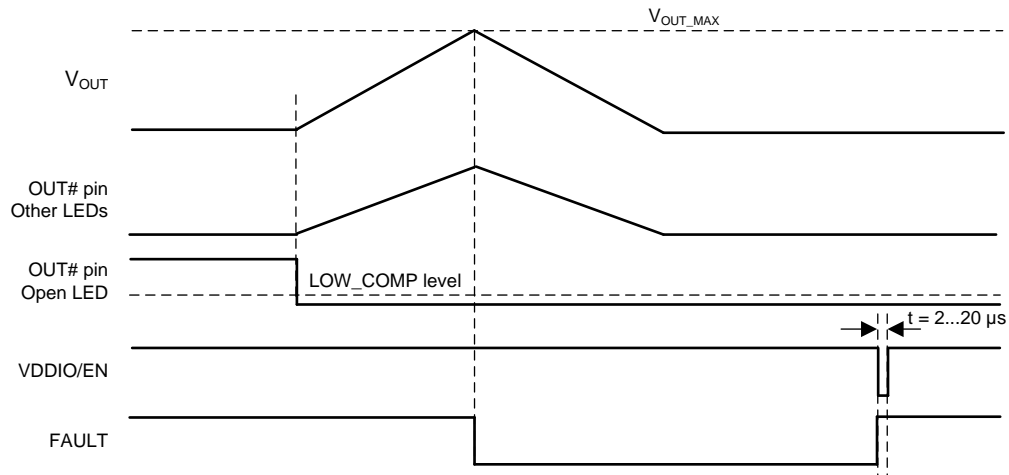
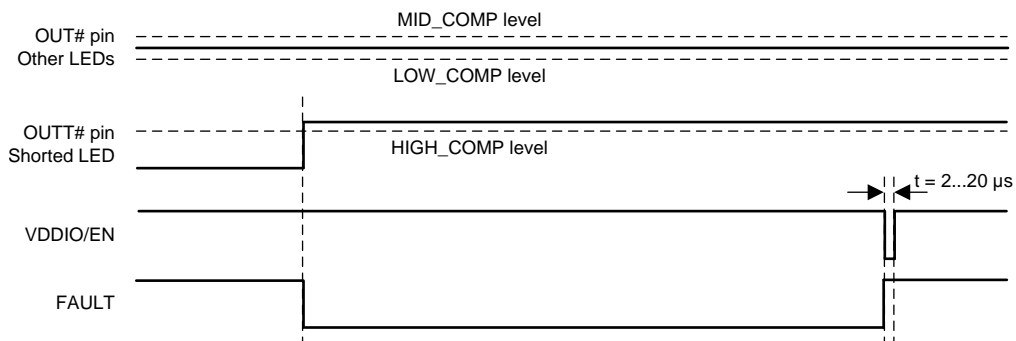

Figure 13. V_{IN} Undervoltage Lockout

Figure 14. LED Open Fault

Figure 15. LED Short Fault

7.4 Device Functional Modes

7.4.1 Device States

TPS61193-Q1 enters STANDBY mode when the internal LDO output rises above the power-on reset level, $V_{LDO} > V_{POR}$. In STANDBY mode device is able to detect VDDIO/EN signal. When VDDIO/EN is pulled high, device powers up. After start LED outputs are sensed to detect grounded outputs. Grounded outputs are disabled and excluded from the adaptive voltage control loop of the DC-DC.

If a fault condition is detected, device enters FAULT_RECOVERY state. Faults that cause the device to enter FAULT_RECOVERY are listed in [Table 3](#). When LED open or short is detected, faulty string is disabled but device stays in ACTIVE mode.

Device Functional Modes (continued)

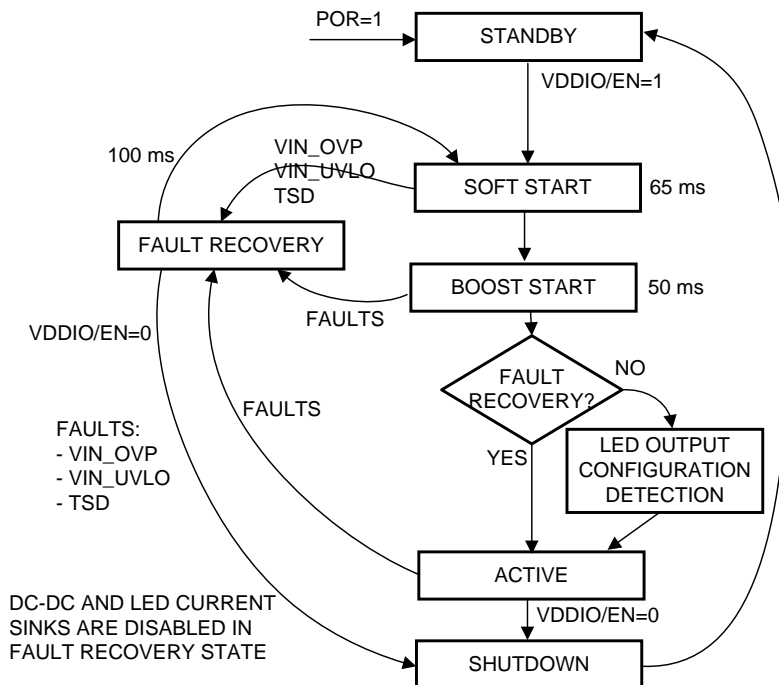

Figure 16. State Diagram

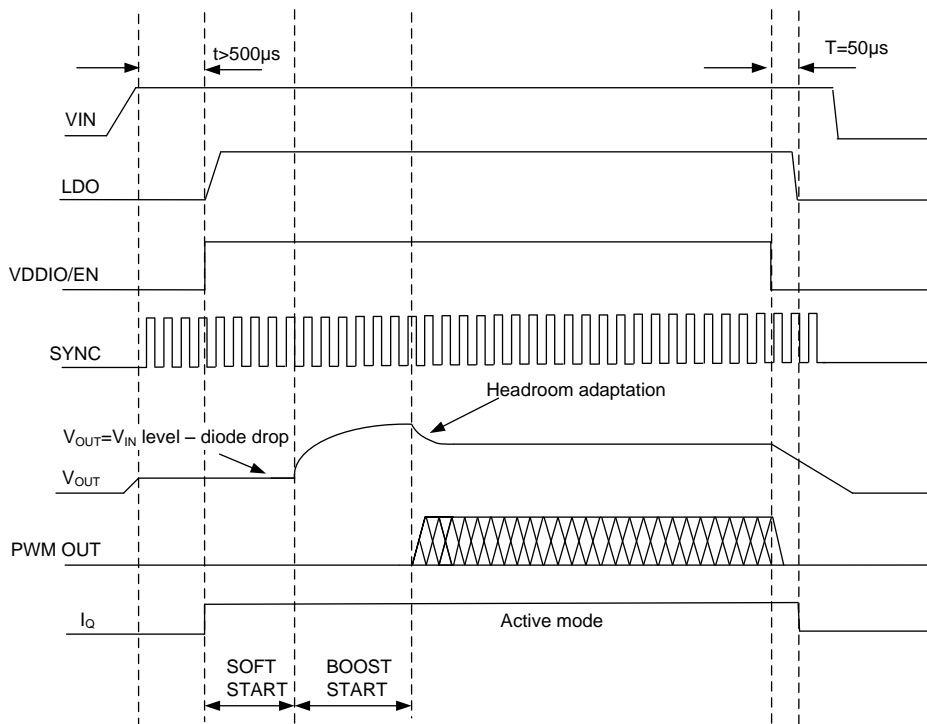

Figure 17. Timing Diagram for the Typical Start-Up and Shutdown

Typical Applications (continued)

8.2.1.1 Design Requirements

DESIGN PARAMETER	VALUE
V _{IN} voltage range	4.5...28 V
LED string	3P8S LEDs (30 V)
LED string current	100 mA
Maximum boost voltage	37 V
Boost switching frequency	300 kHz
External boost sync	not used
Boost spread spectrum	enabled
L1	33 μH
C _{IN}	10 μF 50 V
C _{IN BOOST}	2 × (10 μF 50-V ceramic) + 33 μF 50-V electrolytic
C _{OUT}	2 × (10 μF 50-V ceramic) + 33 μF 50-V electrolytic
C _{FB}	15 pF
C _{LDO}	1 μF 10 V
R _{ISET}	24 kΩ
R _{FSET}	210 kΩ
R1	750 kΩ
R2	130 kΩ
R3	10 kΩ

8.2.1.2 Detailed Design Procedure

8.2.1.2.1 Inductor Selection

There are two main considerations when choosing an inductor; the inductor should not saturate, and the inductor current ripple should be small enough to achieve the desired output voltage ripple. Different saturation current rating specifications are followed by different manufacturers so attention must be given to details. Saturation current ratings are typically specified at 25°C. However, ratings at the maximum ambient temperature of application should be requested from the manufacturer. Shielded inductors radiate less noise and should be preferred. The saturation current should be greater than the sum of the maximum load current and the worst case average to peak inductor current. The equation below shows the worst case conditions

$$I_{SAT} > \frac{I_{OUTMAX}}{D'} + I_{RIPPLE} \quad \text{For Boost}$$

$$\text{Where } I_{RIPPLE} = \frac{(V_{OUT} - V_{IN})}{(2 \times L \times f)} \times \frac{V_{IN}}{V_{OUT}}$$

$$\text{Where } D = \frac{(V_{OUT} - V_{IN})}{(V_{OUT})} \text{ and } D' = (1 - D)$$

- I_{RIPPLE} - peak inductor current
- I_{OUTMAX} - maximum load current
- V_{IN} - minimum input voltage in application
- L - min inductor value including worst case tolerances
- f - minimum switching frequency
- V_{OUT} - output voltage
- D - Duty Cycle for CCM Operation
- V_{OUT} - Output Voltage

(4)

As a result the inductor should be selected according to the I_{SAT}. A more conservative and recommended approach is to choose an inductor that has a saturation current rating greater than the maximum current limit. A saturation current rating of at least 2.5 A is recommended for most applications. See [Table 2](#) for recommended inductance value for the different switching frequency ranges. The inductor's resistance should be less than

300 mΩ for good efficiency.

See detailed information in Texas Instruments Application Report *Understanding Boost Power Stages in Switch Mode Power Supplies (SLVA061)*. *Power Stage Designer™ Tool* can be used for the boost calculation: <http://www.ti.com/tool/powerstage-designer>.

8.2.1.2.2 Output Capacitor Selection

A ceramic capacitor with $2 \times V_{MAX_BOOST}$ or more voltage rating is recommended for the output capacitor. The DC-bias effect can reduce the effective capacitance by up to 80%, which needs to be considered in capacitance value selection. Capacitance recommendations for different switching frequencies are shown in Table 2. To minimize audible noise of ceramic capacitors their physical size should typically be minimized.

8.2.1.2.3 Input Capacitor Selection

A ceramic capacitor with $2 \times V_{IN_MAX}$ or more voltage rating is recommended for the input capacitor. The DC-bias effect can reduce the effective capacitance by up to 80%, which needs to be considered in capacitance value selection. Capacitance recommendations for different boost switching frequencies are shown in Table 2.

8.2.1.2.4 LDO Output Capacitor

A ceramic capacitor with at least 10-V voltage rating is recommended for the output capacitor of the LDO. The DC-bias effect can reduce the effective capacitance by up to 80%, which needs to be considered in capacitance value selection. Typically a 1-μF capacitor is sufficient.

8.2.1.2.5 Diode

A Schottky diode should be used for the boost output diode. Do not use ordinary rectifier diodes because slow switching speeds and long recovery times degrade the efficiency and the load regulation. Diode rating for peak repetitive current should be greater than inductor peak current (up to 3 A) to ensure reliable operation in boost mode. Average current rating should be greater than the maximum output current. Schottky diodes with a low forward drop and fast switching speeds are ideal for increasing efficiency. Choose a reverse breakdown voltage of the Schottky diode significantly larger than the output voltage.

8.2.1.3 Application Curves

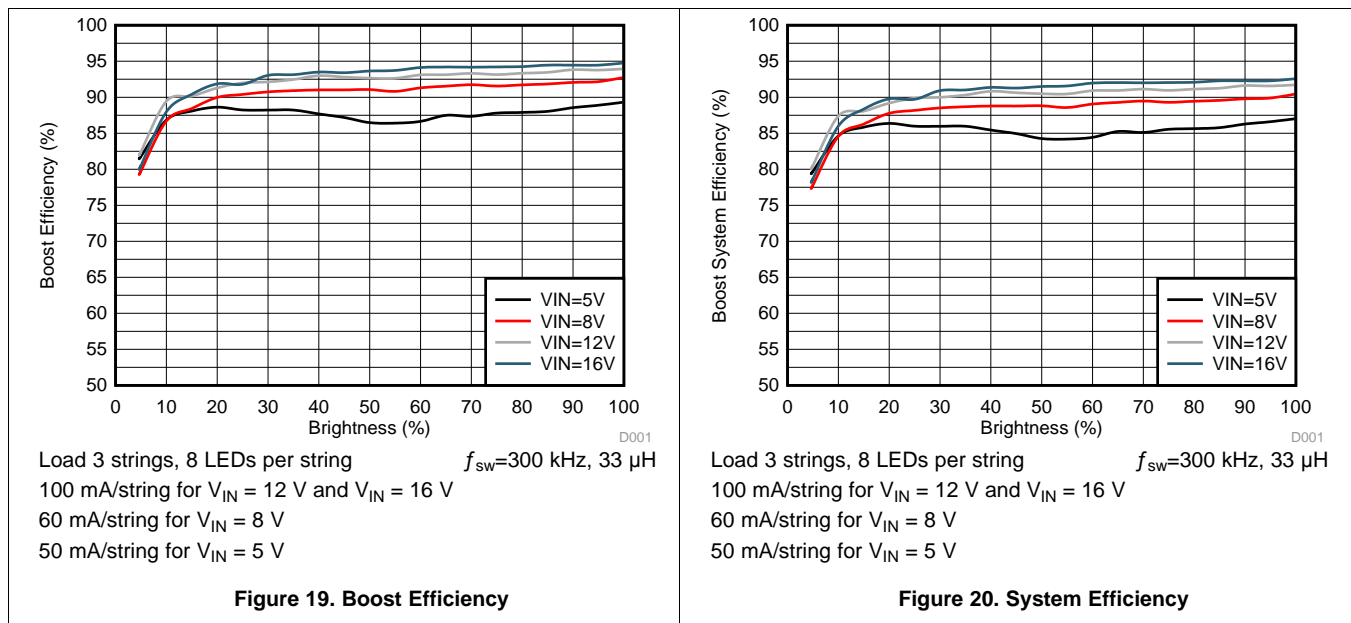

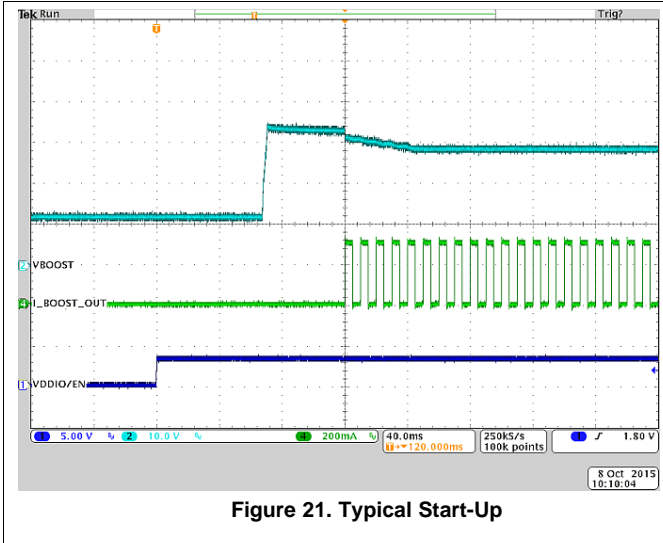

Figure 21. Typical Start-Up

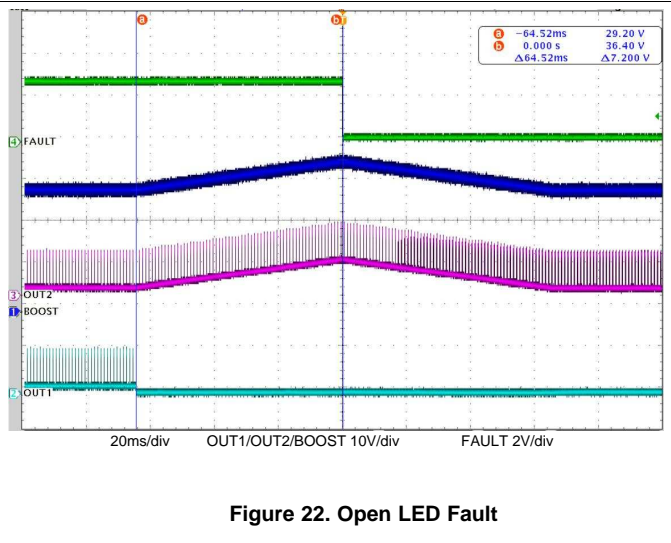

Figure 22. Open LED Fault

8.2.2 SEPIC Mode Application

When LED string voltage can be above or below V_{IN} voltage, SEPIC configuration can be used. In this example, two separate coils are used for SEPIC. This can enable lower height external components to be used, compared to a coupled coil solution. On the other hand, coupled coil typically maximizes the efficiency. Also, in this example, an external clock is used to synchronize SEPIC switching frequency. External clock input can be modulated to spread switching frequency spectrum.

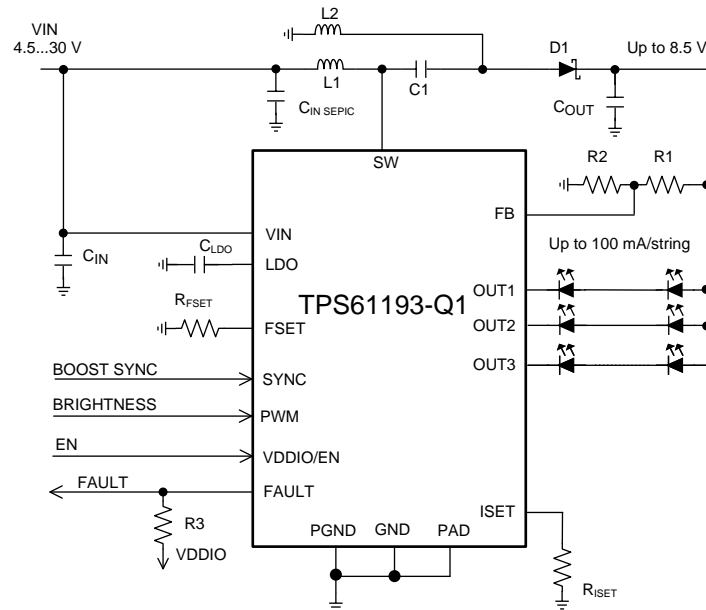

Figure 23. SEPIC Mode, 3 Strings, 100 mA/String Configuration

8.2.2.1 Design Requirements

DESIGN PARAMETER	VALUE
V_{IN} voltage range	4.5...30 V
LED string	3P2S LEDs (7.2 V)
LED string current	100 mA
Maximum output voltage	10 V
SEPIC switching frequency	2.2 MHz
External sync for SEPIC	used
Spread spectrum	Internal spread spectrum disabled (external sync used)
L1, L2	10 μ H
C_{IN}	10 μ F 50 V
$C_{IN\ SEPIC}$	2 \times (10 μ F 50-V ceramic) + 33 μ F 50-V electrolytic
C1	10 μ F 50V ceramic
C_{OUT}	2 \times (10 μ F 50-V ceramic) + 33 μ F 50-V electrolytic
C_{LDO}	1 μ F 10-V
R_{ISET}	24 k Ω
R_{FSET}	24 k Ω
R1	184 k Ω
R2	130 k Ω
R3	10 k Ω

8.2.2.2 Detailed Design Procedure

In SEPIC mode the maximum voltage at the SW pin is equal to the sum of the input voltage and the output voltage. Because of this, the maximum sum of input and output voltage must be limited below 50 V. See [Detailed Design Procedure](#) for general external component guidelines. Main differences of SEPIC compared to boost are described below.

Power Stage Designer™ Tool can be used for modeling SEPIC behavior: <http://www.ti.com/tool/powerstage-designer>. For detailed explanation on SEPIC see Texas Instruments Analog Applications Journal *Designing DC/DC Converters Based on SEPIC Topology (SLYT309)*.

8.2.2.2.1 Inductor

In SEPIC mode, currents flowing through the coupled inductors or the two separate inductors L1 and L2 are the input current and output current, respectively. Values can be calculated using *Power Stage Designer™ Tool* or using equations in [SLYT309](#).

8.2.2.2.2 Diode

In SEPIC mode diode peak current is equal to the sum of input and output currents. Diode rating for peak repetitive current should be greater than SW pin current limit (up to 3 A for transients) to ensure reliable operation in boost mode. Average current rating should be greater than the maximum output current. Diode voltage rating must be higher than sum of input and output voltages.

8.2.2.2.3 Capacitor C1

Ceramic capacitor with low ESR is recommended. Diode voltage rating must be higher than maximum input voltage.

8.2.2.3 Application Curves

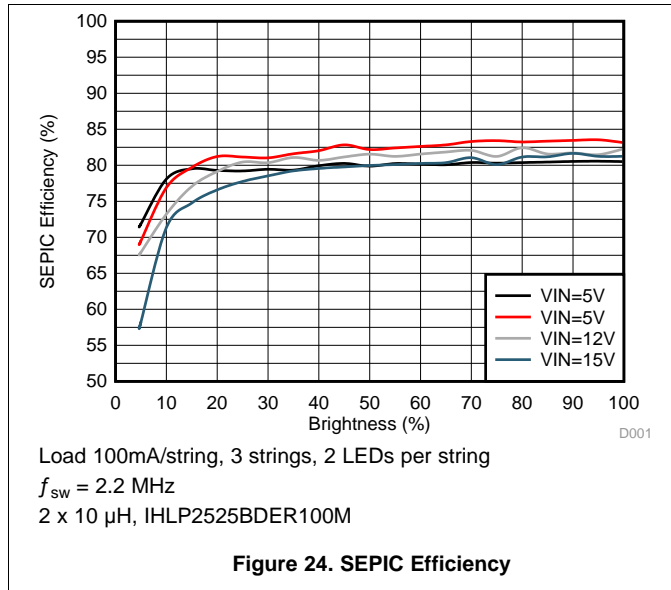

Figure 24. SEPIC Efficiency

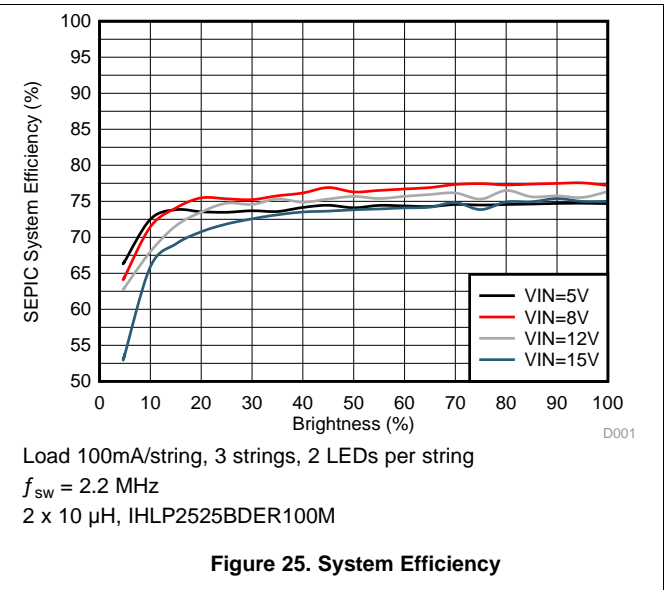

Figure 25. System Efficiency

9 Power Supply Recommendations

The device is designed to operate from an automotive battery. Device should be protected from reversal voltage and voltage dump over 50 V. The resistance of the input supply rail must be low enough so that the input current transient does not cause too high drop at TPS61193-Q1 VIN pin. If the input supply is connected by using long wires additional bulk capacitance may be required in addition to the ceramic bypass capacitors in the V_{IN} line.

10 Layout

10.1 Layout Guidelines

Figure 26 is a layout recommendation for TPS61193-Q1 used to demonstrate the principles of a good layout. This layout can be adapted to the actual application layout if or where possible. It is important that all boost components are close to the chip, and the high current traces must be wide enough. By placing boost components on one side of the chip it is easy to keep the ground plane intact below the high current paths. This way other chip pins can be routed more easily without splitting the ground plane. Bypass LDO capacitor should be as close to the device as possible.

Here are some main points to help the PCB layout work:

- Current loops need to be minimized:
 - For low frequency the minimal current loop can be achieved by placing the boost components as close as possible to the SW and PGND pins. Input and output capacitor grounds need to be close to each other to minimize current loop size.
 - Minimal current loops for high frequencies can be achieved by making sure that the ground plane is intact under the current traces. High frequency return currents try to find route with minimum impedance, which is the route with minimum loop area, not necessarily the shortest path. Minimum loop area is formed when return current flows just under the “positive” current route in the ground plane, if the ground plane is intact under the route.
- The GND plane needs to be intact under the high current boost traces to provide shortest possible return path and smallest possible current loops for high frequencies.
- Current loops when the boost switch is conducting and not conducting need to be on the same direction in optimal case.
- Inductors must be placed so that the current flows in the same direction as in the current loops. Rotating inductor 180° changes current direction.
- Use separate power and noise-free grounds. Power ground is used for boost converter return current and noise-free ground for more sensitive signals, like LDO bypass capacitor grounding as well as grounding the GND pin of the device itself.
- Boost output feedback voltage to LEDs need to be taken out *after* the output capacitors, not straight from the diode cathode.
- Place LDO 1- μ F bypass capacitor as close to the LDO pin as possible.
- Input and output capacitors need strong grounding (wide traces, many vias to GND plane).
- If two output capacitors are used they need symmetrical layout to get both capacitors working ideally.
- Output ceramic capacitors have DC-bias effect. If the output capacitance is too low, it can cause boost to become unstable on some loads, and this increases EMI. DC-bias characteristics need to be obtained from the component manufacturer; it is not taken into account on component tolerance. X5R/X7R capacitors are recommended.

10.2 Layout Example

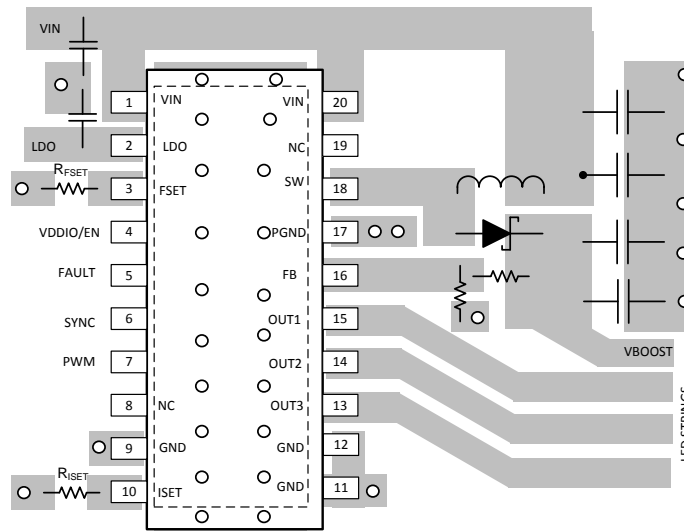

Figure 26. TPS61193-Q1 Boost Layout

11 Device and Documentation Support

11.1 Documentation Support

11.1.1 Related Documentation

For related documentation see the following:

- *Using the TPS61193EVM and TPS61193-Q1EVM Evaluation Module* ([SNVU491](#))
- *PowerPAD™ Thermally Enhanced Package Application Note* ([SLMA002](#))
- Texas Instruments Application Report *Understanding Boost Power Stages in Switch Mode Power Supplies* ([SLVA061](#))
- Texas Instruments Analog Applications Journal *Designing DC/DC Converters Based on SEPIC Topology* ([SLYT309](#))
- Power Stage Designer™ Tool can be used for both boost and SEPIC: <http://www.ti.com/tool/powerstage-designer>

11.2 Trademarks

11.3 Electrostatic Discharge Caution



These devices have limited built-in ESD protection. The leads should be shorted together or the device placed in conductive foam during storage or handling to prevent electrostatic damage to the MOS gates.

11.4 Glossary

[SLYZ022](#) — *TI Glossary*.

This glossary lists and explains terms, acronyms, and definitions.

12 Mechanical, Packaging, and Orderable Information

The following pages include mechanical, packaging, and orderable information. This information is the most current data available for the designated devices. This data is subject to change without notice and revision of this document. For browser-based versions of this data sheet, refer to the left-hand navigation.

PACKAGING INFORMATION

Orderable Device	Status (1)	Package Type	Package Drawing	Pins	Package Qty	Eco Plan (2)	Lead/Ball Finish (6)	MSL Peak Temp (3)	Op Temp (°C)	Device Marking (4/5)	Samples
TPS61193PWPRQ1	ACTIVE	HTSSOP	PWP	20	2000	Green (RoHS & no Sb/Br)	CU NIPDAU	Level-2-260C-1 YEAR	-40 to 125	61193Q	Samples

(1) The marketing status values are defined as follows:

ACTIVE: Product device recommended for new designs.

LIFEBUY: TI has announced that the device will be discontinued, and a lifetime-buy period is in effect.

NRND: Not recommended for new designs. Device is in production to support existing customers, but TI does not recommend using this part in a new design.

PREVIEW: Device has been announced but is not in production. Samples may or may not be available.

OBSOLETE: TI has discontinued the production of the device.

(2) Eco Plan - The planned eco-friendly classification: Pb-Free (RoHS), Pb-Free (RoHS Exempt), or Green (RoHS & no Sb/Br) - please check <http://www.ti.com/productcontent> for the latest availability information and additional product content details.

TBD: The Pb-Free/Green conversion plan has not been defined.

Pb-Free (RoHS): TI's terms "Lead-Free" or "Pb-Free" mean semiconductor products that are compatible with the current RoHS requirements for all 6 substances, including the requirement that lead not exceed 0.1% by weight in homogeneous materials. Where designed to be soldered at high temperatures, TI Pb-Free products are suitable for use in specified lead-free processes.

Pb-Free (RoHS Exempt): This component has a RoHS exemption for either 1) lead-based flip-chip solder bumps used between the die and package, or 2) lead-based die adhesive used between the die and leadframe. The component is otherwise considered Pb-Free (RoHS compatible) as defined above.

Green (RoHS & no Sb/Br): TI defines "Green" to mean Pb-Free (RoHS compatible), and free of Bromine (Br) and Antimony (Sb) based flame retardants (Br or Sb do not exceed 0.1% by weight in homogeneous material)

(3) MSL, Peak Temp. - The Moisture Sensitivity Level rating according to the JEDEC industry standard classifications, and peak solder temperature.

(4) There may be additional marking, which relates to the logo, the lot trace code information, or the environmental category on the device.

(5) Multiple Device Markings will be inside parentheses. Only one Device Marking contained in parentheses and separated by a "~" will appear on a device. If a line is indented then it is a continuation of the previous line and the two combined represent the entire Device Marking for that device.

(6) Lead/Ball Finish - Orderable Devices may have multiple material finish options. Finish options are separated by a vertical ruled line. Lead/Ball Finish values may wrap to two lines if the finish value exceeds the maximum column width.

Important Information and Disclaimer: The information provided on this page represents TI's knowledge and belief as of the date that it is provided. TI bases its knowledge and belief on information provided by third parties, and makes no representation or warranty as to the accuracy of such information. Efforts are underway to better integrate information from third parties. TI has taken and continues to take reasonable steps to provide representative and accurate information but may not have conducted destructive testing or chemical analysis on incoming materials and chemicals. TI and TI suppliers consider certain information to be proprietary, and thus CAS numbers and other limited information may not be available for release.

In no event shall TI's liability arising out of such information exceed the total purchase price of the TI part(s) at issue in this document sold by TI to Customer on an annual basis.

OTHER QUALIFIED VERSIONS OF TPS61193-Q1 :

- Catalog: [TPS61193](#)

NOTE: Qualified Version Definitions:

- Catalog - TI's standard catalog product

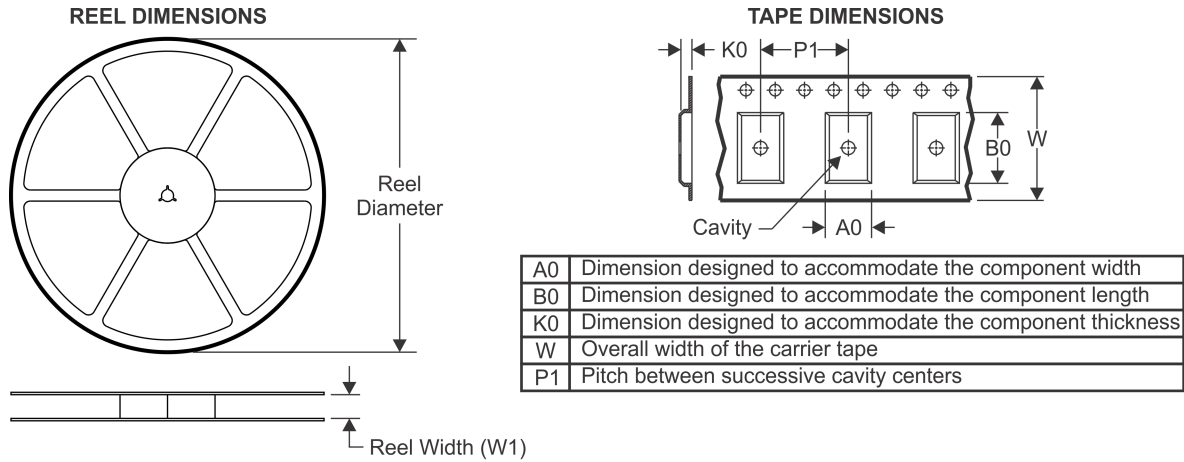
TAPE AND REEL INFORMATION

QUADRANT ASSIGNMENTS FOR PIN 1 ORIENTATION IN TAPE

*All dimensions are nominal

Device	Package Type	Package Drawing	Pins	SPQ	Reel Diameter (mm)	Reel Width W1 (mm)	A0 (mm)	B0 (mm)	K0 (mm)	P1 (mm)	W (mm)	Pin1 Quadrant
TPS61193PWPRQ1	HTSSOP	PWP	20	2000	330.0	16.4	6.95	7.1	1.6	8.0	16.0	Q1

TAPE AND REEL BOX DIMENSIONS



*All dimensions are nominal

Device	Package Type	Package Drawing	Pins	SPQ	Length (mm)	Width (mm)	Height (mm)
TPS61193PWPRQ1	HTSSOP	PWP	20	2000	367.0	367.0	38.0

THERMAL PAD MECHANICAL DATA

PWP (R-PDSO-G20) PowerPAD™ SMALL PLASTIC OUTLINE

THERMAL INFORMATION

This PowerPAD™ package incorporates an exposed thermal pad that is designed to be attached to a printed circuit board (PCB). The thermal pad must be soldered directly to the PCB. After soldering, the PCB can be used as a heatsink. In addition, through the use of thermal vias, the thermal pad can be attached directly to the appropriate copper plane shown in the electrical schematic for the device, or alternatively, can be attached to a special heatsink structure designed into the PCB. This design optimizes the heat transfer from the integrated circuit (IC).

For additional information on the PowerPAD package and how to take advantage of its heat dissipating abilities, refer to Technical Brief, PowerPAD Thermally Enhanced Package, Texas Instruments Literature No. SLMA002 and Application Brief, PowerPAD Made Easy, Texas Instruments Literature No. SLMA004. Both documents are available at www.ti.com.

The exposed thermal pad dimensions for this package are shown in the following illustration.

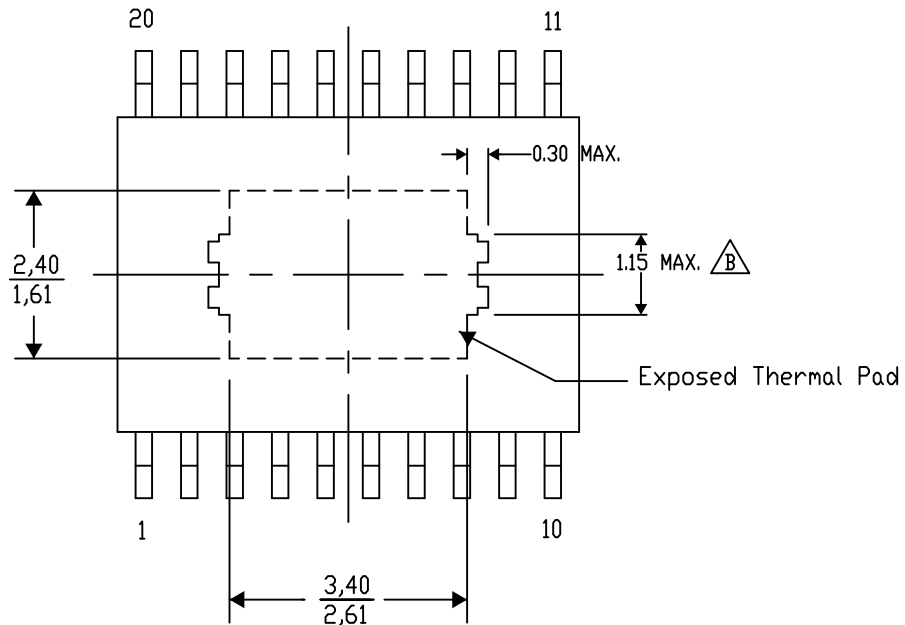

4206332-15/AN 10/15

NOTE: A. All linear dimensions are in millimeters

 Exposed tie strap features may not be present.

PowerPAD is a trademark of Texas Instruments

PWP (R-PDSO-G20)

PowerPAD™ PLASTIC SMALL OUTLINE

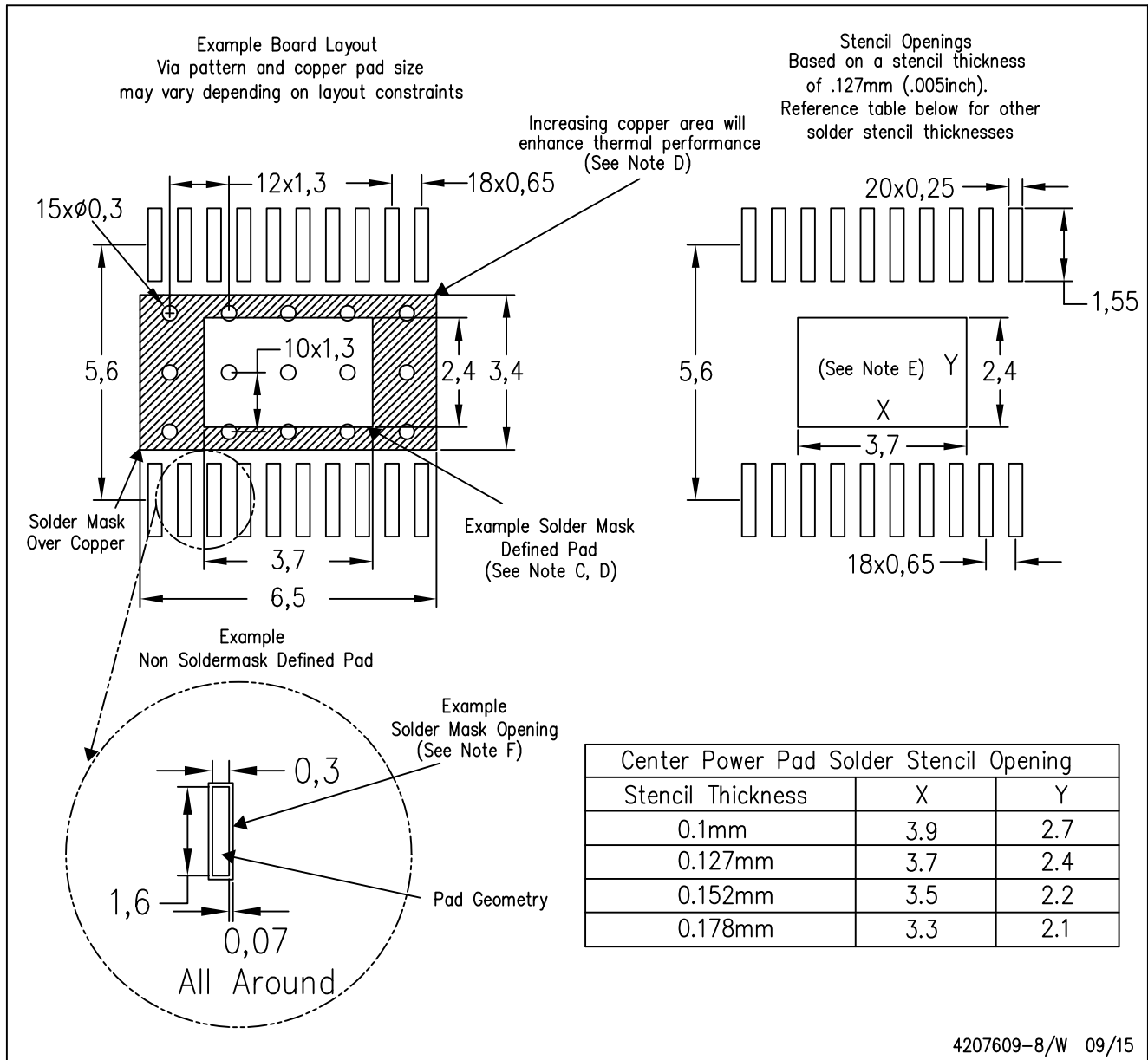

- NOTES:
- A. All linear dimensions are in millimeters.
 - B. This drawing is subject to change without notice.
 - C. Customers should place a note on the circuit board fabrication drawing not to alter the center solder mask defined pad.
 - D. This package is designed to be soldered to a thermal pad on the board. Refer to Technical Brief, PowerPad Thermally Enhanced Package, Texas Instruments Literature No. SLMA002, SLMA004, and also the Product Data Sheets for specific thermal information, via requirements, and recommended board layout. These documents are available at www.ti.com <<http://www.ti.com>>. Publication IPC-7351 is recommended for alternate designs.
 - E. Laser cutting apertures with trapezoidal walls and also rounding corners will offer better paste release. Customers should contact their board assembly site for stencil design recommendations. Example stencil design based on a 50% volumetric metal load solder paste. Refer to IPC-7525 for other stencil recommendations.
 - F. Customers should contact their board fabrication site for solder mask tolerances between and around signal pads.

IMPORTANT NOTICE

Texas Instruments Incorporated and its subsidiaries (TI) reserve the right to make corrections, enhancements, improvements and other changes to its semiconductor products and services per JESD46, latest issue, and to discontinue any product or service per JESD48, latest issue. Buyers should obtain the latest relevant information before placing orders and should verify that such information is current and complete. All semiconductor products (also referred to herein as "components") are sold subject to TI's terms and conditions of sale supplied at the time of order acknowledgment.

TI warrants performance of its components to the specifications applicable at the time of sale, in accordance with the warranty in TI's terms and conditions of sale of semiconductor products. Testing and other quality control techniques are used to the extent TI deems necessary to support this warranty. Except where mandated by applicable law, testing of all parameters of each component is not necessarily performed.

TI assumes no liability for applications assistance or the design of Buyers' products. Buyers are responsible for their products and applications using TI components. To minimize the risks associated with Buyers' products and applications, Buyers should provide adequate design and operating safeguards.

TI does not warrant or represent that any license, either express or implied, is granted under any patent right, copyright, mask work right, or other intellectual property right relating to any combination, machine, or process in which TI components or services are used. Information published by TI regarding third-party products or services does not constitute a license to use such products or services or a warranty or endorsement thereof. Use of such information may require a license from a third party under the patents or other intellectual property of the third party, or a license from TI under the patents or other intellectual property of TI.

Reproduction of significant portions of TI information in TI data books or data sheets is permissible only if reproduction is without alteration and is accompanied by all associated warranties, conditions, limitations, and notices. TI is not responsible or liable for such altered documentation. Information of third parties may be subject to additional restrictions.

Resale of TI components or services with statements different from or beyond the parameters stated by TI for that component or service voids all express and any implied warranties for the associated TI component or service and is an unfair and deceptive business practice. TI is not responsible or liable for any such statements.

Buyer acknowledges and agrees that it is solely responsible for compliance with all legal, regulatory and safety-related requirements concerning its products, and any use of TI components in its applications, notwithstanding any applications-related information or support that may be provided by TI. Buyer represents and agrees that it has all the necessary expertise to create and implement safeguards which anticipate dangerous consequences of failures, monitor failures and their consequences, lessen the likelihood of failures that might cause harm and take appropriate remedial actions. Buyer will fully indemnify TI and its representatives against any damages arising out of the use of any TI components in safety-critical applications.

In some cases, TI components may be promoted specifically to facilitate safety-related applications. With such components, TI's goal is to help enable customers to design and create their own end-product solutions that meet applicable functional safety standards and requirements. Nonetheless, such components are subject to these terms.

No TI components are authorized for use in FDA Class III (or similar life-critical medical equipment) unless authorized officers of the parties have executed a special agreement specifically governing such use.

Only those TI components which TI has specifically designated as military grade or "enhanced plastic" are designed and intended for use in military/aerospace applications or environments. Buyer acknowledges and agrees that any military or aerospace use of TI components which have **not** been so designated is solely at the Buyer's risk, and that Buyer is solely responsible for compliance with all legal and regulatory requirements in connection with such use.

TI has specifically designated certain components as meeting ISO/TS16949 requirements, mainly for automotive use. In any case of use of non-designated products, TI will not be responsible for any failure to meet ISO/TS16949.

Products

Audio	www.ti.com/audio
Amplifiers	amplifier.ti.com
Data Converters	dataconverter.ti.com
DLP® Products	www.dlp.com
DSP	dsp.ti.com
Clocks and Timers	www.ti.com/clocks
Interface	interface.ti.com
Logic	logic.ti.com
Power Mgmt	power.ti.com
Microcontrollers	microcontroller.ti.com
RFID	www.ti-rfid.com
OMAP Applications Processors	www.ti.com/omap
Wireless Connectivity	www.ti.com/wirelessconnectivity

Applications

Automotive and Transportation	www.ti.com/automotive
Communications and Telecom	www.ti.com/communications
Computers and Peripherals	www.ti.com/computers
Consumer Electronics	www.ti.com/consumer-apps
Energy and Lighting	www.ti.com/energy
Industrial	www.ti.com/industrial
Medical	www.ti.com/medical
Security	www.ti.com/security
Space, Avionics and Defense	www.ti.com/space-avionics-defense
Video and Imaging	www.ti.com/video

TI E2E Community

e2e.ti.com